

# ASSEMBLY INSTRUCTIONS

## 2RP9BLKFLR - Floor Standing Literature Display

**Parts List**

- A. Stand Assembly
- B. Acrylic Divider
- C. Literature Rack
- D. Header (sold separately)
- E. Standoff

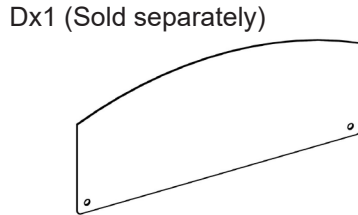
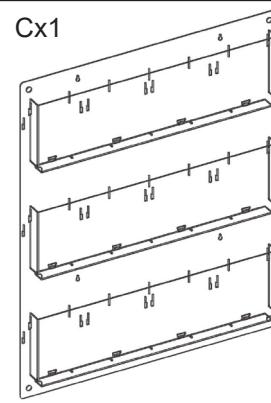
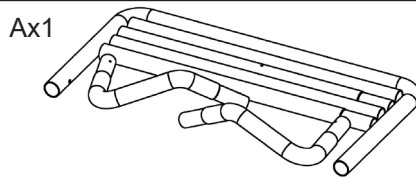

Scan QR code to visit the product page:



2 people are required

**STEP 1.** Insert 2 angled tubes into the base tube. Align the pre-drilled holes in the tubes and secure the base with included screws. Connect the top and bottom upright tubes with the assembled base as shown below. Align holes on the upright tube to the front.

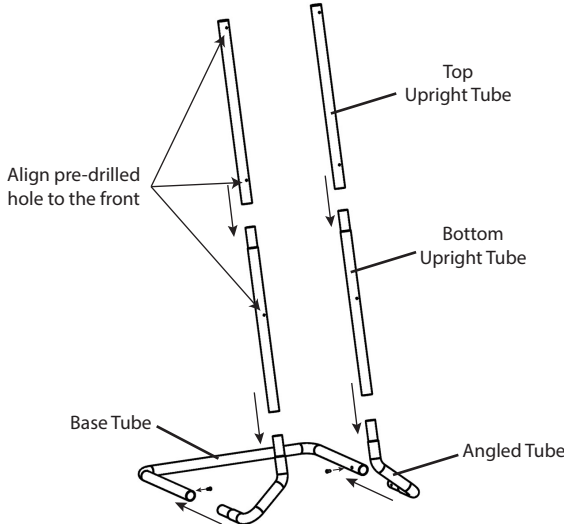

**STEP 2.** Peel off the protective film on each Divider (B). Slide 1 divider down and insert the tab into the slot on the back panel. Rotate the divider and snap it into place. Repeat this step to assemble all dividers that you plan to use.

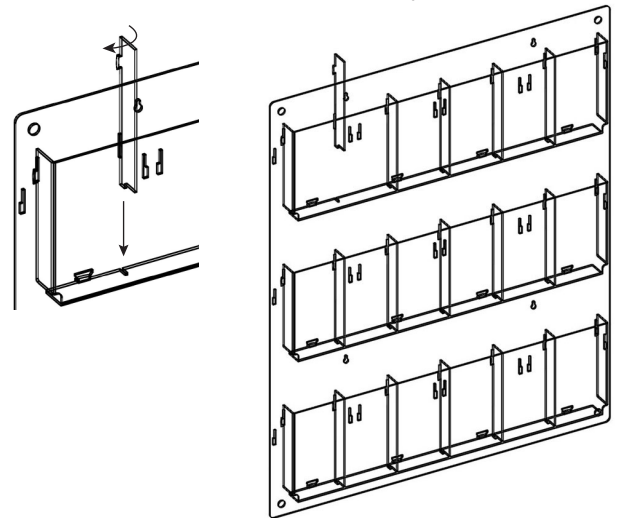

**STEP 3.** Insert 4 screws into the holes on the tubes as shown and assemble with 4 wing nuts from the back. **NOTE: DO NOT** tighten. Carefully lift the Literature Rack (C) and hang the back panel over the screws through the cutout slots. Slide the rack down and make sure that it's secured on the stand.

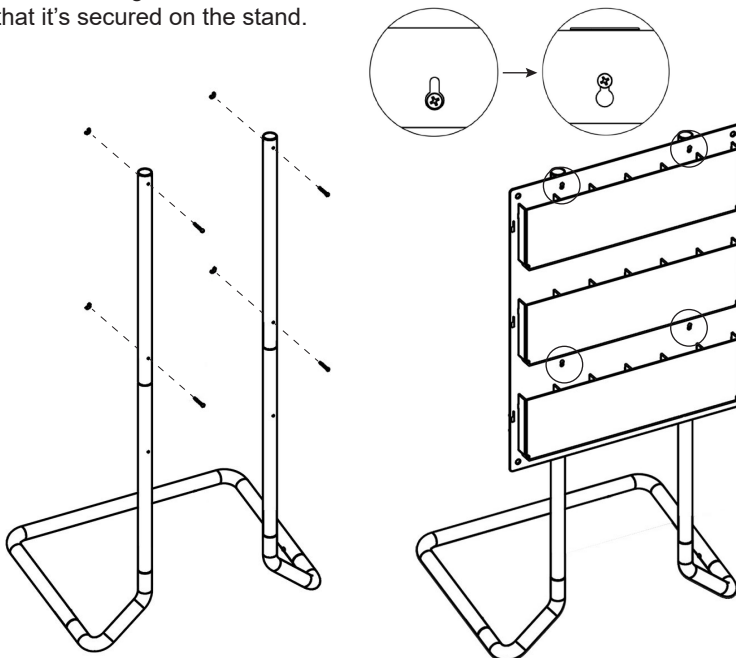

**STEP 4 (Optional)** To assemble the custom printed Acrylic Header (D, sold separately): Align the pre-drilled holes on the header with top 2 holes on the panel. Separate the 2 Standoffs (E), insert 2 standoff caps through the holes on the header and back panel, and secure the acrylic header with 2 standoff bases from the back. Assemble the remaining standoffs as needed.

